



**santosham**<sup>TM</sup>  
retirement community

By Bahri Estates



*Your kind of place  
at  
Your kind of price!*



## The **Developer** ←

Santosham is the brainchild of Mr. Hemant Bahri, the MD of Bahri Estates Pvt. Ltd. He is an eminent member of RICS, (MRICS), London – The world's leading Chartered Qualification for professionals in the land, real estate, construction and infrastructure sector.



Bahri Group is a multi-tiered organization with an experience of over two decades in real estate. Redefined the concept of retirement communities, Our flagship project Anandam at Bahri Beautiful Country redefined the concept of retirement communities and has been awarded as the World's Best Retirement Development at the International Property Awards and the World's Greatest Brands with process review by Pricewaterhouse Coopers.

Going by the great response to the concept of Anandam Retirement Community and the overwhelming customer demand for an affordable version, Mr. Bahri has decided to bring out Santosham Retirement Community. Our communities offer not just retirement homes but also retirement living related services, making the experience a life-long santosham for residents.

# Awards & Recognition



MD - Mr Hemant Bahri receiving  
The World's Greatest Leaders 2015-16 INDIA



MD - Mr Hemant Bahri receiving  
Business Leader of the Year 2015-16



"THE MOST OUTSTANDING RETIREMENT COMMUNITY  
IN THE WORLD IN 2015" GLOBALS



Mr. Hemant Bahri, Managing Director,  
M/s Bahri Estates Pvt Ltd, has been awarded  
The World's Greatest Leaders award

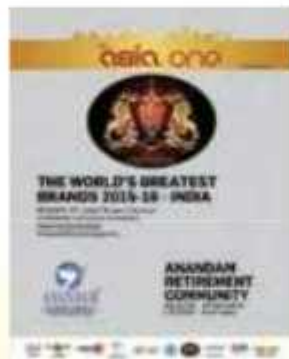

Anandam Retirement Community  
was awarded The World's Greatest  
Brand 2015- 2016



Anandam, was awarded as  
The Most Outstanding Retirement  
Community in the World in 2015



Bahri Estates Pvt. Ltd. awarded as  
The Most Outstanding Seniors Living  
Developer in Asia, 2018.

The good life **you can afford**



Most retired people plan their **retirement savings** but forget to plan their **retirement living**. Santosham Retirement Community by Bahri Estates is an affordable project, located at plot numbers 295-297 within Bahri Beautiful Country, a secured gated community spread over 120 acres of land at the foothills of Kodaikanal.

Bahri Beautiful Country also houses the award winning and fully operational Anandam Retirement Community, providing the best of medical and hospitality services.

Experience a new life after retirement with five star fun.



\* images shown are for illustration purposes only

The good life **you can afford** ←



\* Images shown are for illustration purposes only

# Professionally Managed ← Facilities Operational



Single manned entry and exit gate to maintain privacy



Electronic surveillance, CCTV in common areas



Wide black top roads with street lights



Electricity supply by TNEB



24x7 power backup



Underground electrical and water lines laid throughout the community



Pre-approved for loans available from financial institutions



Battery operated cars for residents



Panchayat water supply



Common facilities are fully operational



\* images shown are for illustration purposes only

# Master plan



**Site Area:**  
4619.23 Sq.m.

**Site Address:** Plot No. 295, 296, 297,  
Bahri Beautiful Country, Gerguvarpatti Village, G. Kalupatti Panchayat,  
Periyakuram Taluk, Thiruv. District, Foothills of Kodaikanal, Tamilnadu.

**DTCP APPROVAL**  
No. 07/2018

Units **1-4** ←

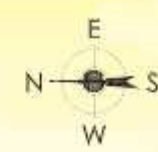

FLOOR PLAN

Key Plan

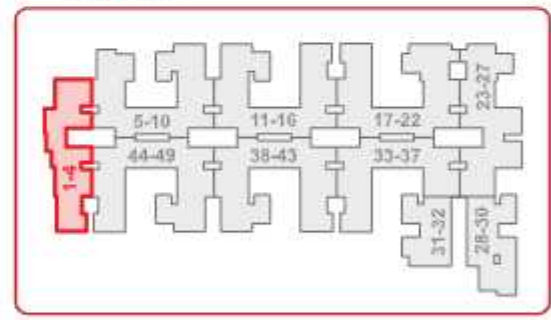

Unit	Type	Built up Area (sqft)	Carpet Area (sqft)	Land UDS
1	1 BHK	330	287	818
2	2 BHK	479	429	1187
3	1 BHK	330	283	818
4	2 BHK	484	429	1200

# Units 5-10

## FLOOR PLAN



Key Plan

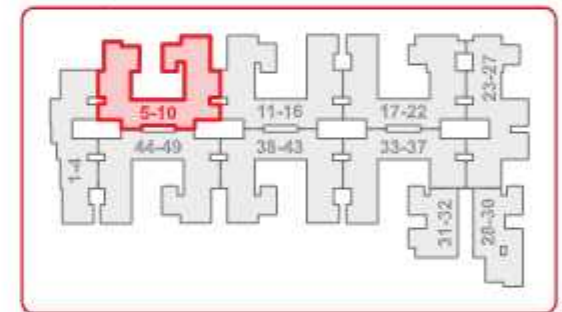

Unit	Type	Built up Area (sqft)	Carpet Area (sqft)	Land UDS
5	1 BHK	329	286	818
6	2 BHK	479	429	1185
7	1 BHK	322	287	798
8	1 BHK	322	287	798
9	2 BHK	479	429	1187
10	2 BHK	492	429	1219

Units **11-16** ←

FLOOR PLAN



Key Plan

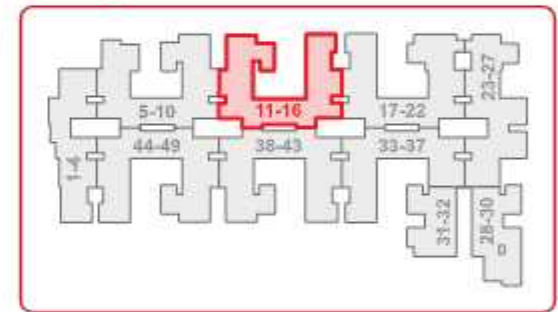

Unit	Type	Built up Area (sqft)	Carpet Area (sqft)	Land UDS
11	2 BHK	492	429	1219
12	2 BHK	479	429	1187
13	1 BHK	322	287	798
14	1 BHK	322	287	798
15	2 BHK	479	429	1187
16	1 BHK	330	287	818

# Units 17-22

## FLOOR PLAN

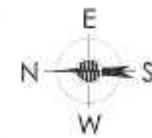

Key Plan

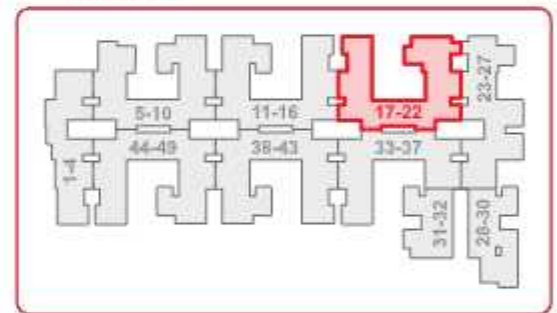

Unit	Type	Built up Area (sqft)	Carpet Area (sqft)	Land UDS
17	1 BHK	330	287	818
18	2 BHK	479	429	1187
19	1 BHK	322	287	798
20	1 BHK	322	287	798
21	2 BHK	479	429	1187
22	2 BHK	489	435	1214

Units **23-27** ←



FLOOR PLAN

Key Plan

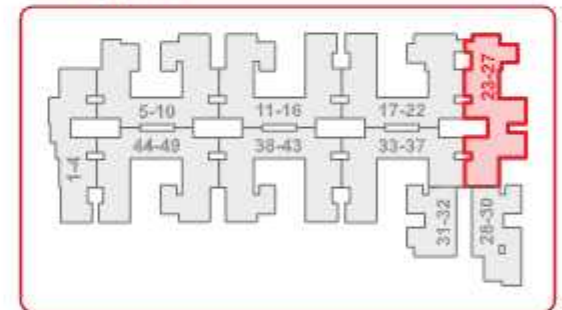

Unit	Type	Built up Area (sqft)	Carpet Area (sqft)	Land UDS
23	2 BHK	496	431	1229
24	2 BHK	479	429	1187
25	1 BHK	326	287	810
26	1 BHK	326	287	810
27	2 BHK	479	429	1187

Units **28-32** ←

FLOOR PLAN



Key Plan

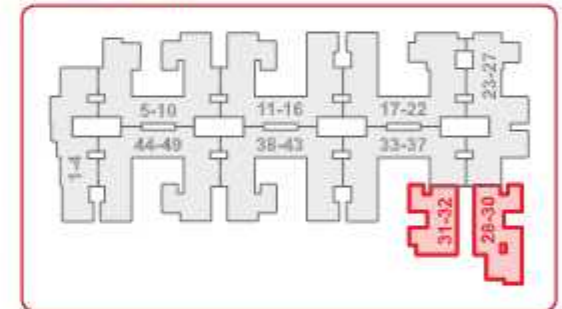

Unit	Type	Built up Area (sqft)	Carpet Area (sqft)	Land UDS
28	2 BHK	487	429	1205
29	2 BHK	489	432	1212
30	1 BHK	329	286	815
31	2 BHK	494	438	1224
32	2 BHK	487	429	1205

Units **33-37** ←

FLOOR PLAN

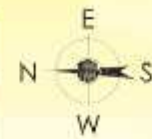

Key Plan

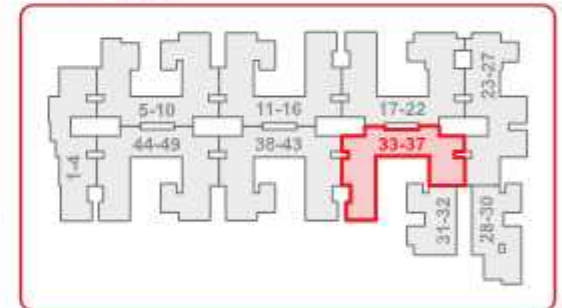

Unit	Type	Built up Area (sqft)	Carpet Area (sqft)	Land UDS
33	2 BHK	479	429	1182
34	1 BHK	322	287	798
35	1 BHK	322	287	798
36	2 BHK	479	429	1187
37	1 BHK	330	287	818

# Units 38-43

## FLOOR PLAN

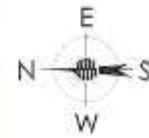

### Key Plan

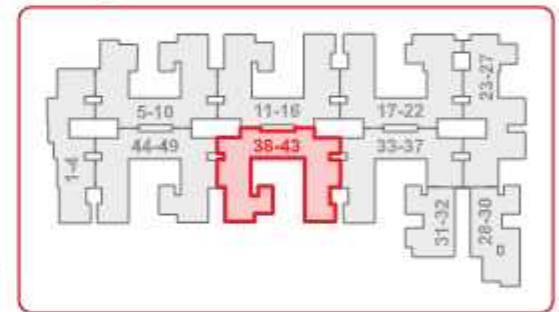

Unit	Type	Built up Area (sqft)	Carpet Area (sqft)	Land UDS
38	1 BHK	330	287	818
39	2 BHK	479	429	1190
40	1 BHK	322	287	798
41	1 BHK	322	287	798
42	2 BHK	479	429	1187
43	2 BHK	492	429	1219

# Units 44-49

## FLOOR PLAN



### Key Plan

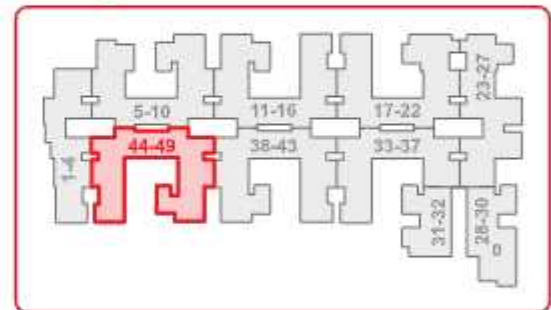

Unit	Type	Built up Area (sqft)	Carpet Area (sqft)	Land UDS
44	2 BHK	492	429	1219
45	2 BHK	479	429	1187
46	1 BHK	322	287	798
47	1 BHK	322	287	798
48	2 BHK	479	429	1185
49	1 BHK	330	287	820

# Project Specification

LOCATION	WALLS	FLOORING	WINDOWS	OTHERS
Living Room	Acrylic Emulsion Paint	Anti Skid Vitrified porcelain tiles	UPVC Windows	-
Bedroom				
Kitchenette	2' High Ceramic Tiles above countertop, rest Acrylic-Emulsion paint			
Toilets	Ceramic Tiles upto 7' height		Vitreous Ceramic Closet and Wash basin with diverter system for shower	
Common Toilet			Vitreous Ceramic Closet and Corner Wash basin	
Doors	Melamine Moulded Panel Doors			
External Facade	Weather proof paint			
Electrical	3 Phase Power Supply concealed copper wiring with PVC insulated wires. PVC conduits and Modular Switches and DB of Good Quality.			
Facilities	Power Backup, Treated Water Supply, Senior Friendly design			



# The club **Culture**



- Health Club
- Lawn Tennis
- Swimming pool
- Snooker
- Restaurant
- Billiards
- Coffee Shop
- Amphitheatre
- Card Room
- Spa
- Saloon
- Gymnasium
- Library
- Yoga Centre
- Table Tennis
- Entertainment Room



**Disclaimer:** The Club Facilities are for the entire project. Club Services will be provided in phases depending upon the occupancy demand and financial feasibility. Clubhouse membership is required to access club facilities.

\* Images shown are for illustration purposes only

# Club work in progress



• Photos taken as on 1st Nov 2019

# Santosham work in progress



Villas Under Construction at Site



Foundation works (footings with RCC & stub column up to plinth beam bottom) for entire length of all cluster service corridor area completed.



\* Photos taken as on 1st Nov 2019

# Santosham work in progress



Transformer yard foundation works completed. HT Cable trench work in progress and main underground water supply line from tapping point to Santosham project has been laid completely, tested and commissioned.



\* Photos taken as on 1st Nov 2019

# Professional hospitality & facilities



Bahri Realty Management was established by Bahri Estates Pvt. Ltd. At Bahri Realty, we believe that you deserve a hassle-free life created to suit the way you decide to live it. We ensure to make your daily life easier, by offering dedicated service and care as per your needs and preferences. Our motto is to provide services tailor-made to each individual's unique needs.

It is a matter of great pride that Bahri's earlier retirement project, Anandam Retirement Community which is being managed by Bahri Realty Management Services was awarded "The World's Greatest Brand 2015-16" by Consumer & Industry, and several other national and international recognitions.

## Hospitality

Our staff will get to know and understand you fully - your likes and dislikes, Your pet peeves, your favourite meals, your hobbies, your background, your sense of humour and whatever else you'd like to share.

## Housekeeping

You may choose to hire the services to perform household cleaning, cooking, home maintenance, shopping, laundry and bill payments.

## Concierge

We offer concierge desk within the Clubhouse for the utilization of the residents

## Assisted Living

We understand that you need loving care and support for your living routine. Thoughtful assistance is provided for a whole list of activity and at a very reasonable cost.

## Tailormade Services

This includes Assisted Living, Central Dining, Calendar-based Activities, Apollo Tele-Health Services, Purchase Service, CCTV Monitoring, Pest Control, Horticulture Service, Waste Management, In-house Maintenance, Gardening, Move-in Assistance, Lease, Rental & Sale of Properties, Periodic Awareness Programs and Car Care.



Realty Team at Bahri Beautiful Country

# Hospitality & maintenance



# Hospitality & **maintenance**



# Calendar-based activities



Pongal celebration



Independence day celebration



Health awareness



Birthday celebration

Calendar-based **activities** ←



**Chef of the day**



**Diwali Celebration**



**Elders day celebration**



**Mothers Day Celebration**

## Health **services** ←

Qualified staff is already present at the medical center, along with a state of the art ambulance on the campus. Health checkups are also conducted on a regular basis.



## Ayurvedic **therapies**



**Dr. Danny Devasy**  
General Manager - Operations

At Santosham, we are providing Traditional Ayurveda therapies that are best suited for age-related issues like Osteoarthritis, fatigue, stiffness and pain in body. The therapy services are rendered by experienced male and female Ayurveda masseurs from Kerala.

It is a double blessing that Dr. Danny Devasy, the General Manager – Operations at Bahri Realty Management Services, is a qualified doctor in Ayurvedic medicine and a certified Clinical Nutritionist.



**Abhyangam**



**Sirodhara**

# Testimonials



**Dr. Gopalakrishnan**

Marketing & Sales Head, Fourrts India

Santosham Retirement Community gives a very comprehensive package for all senior citizens and they answer all the concerns a senior citizen has. Here a senior citizen would enjoy independent living while keeping up his dignity and at the same time giving him or her all possible comfort. At Santosham there is an excellent ambience, very good food, recreations facilities, health facilities, housekeeping and more. Whatever we look forward to make life independent and pleasurable is present. Santosham in every way will give happiness, peace and tranquillity to all senior citizens.



**Mrs Shirin Mammen**

Consultant - Disabilities Practitioner

My children are living abroad. I think it is most essential to have this concept of a retirement home since i feel that they may not have much time to spend and take care once we get older and time passes when we need more physical and medical help. This is what made me think about a retirement community. The concept of Santosham is what i prefer is because i find it to be very inclusive and since i am single these compact villas are suitable for me. The location and the backdrop of the hills is incomparable.



**Mr & Mrs Jagannmohnan**

(MD (Rtd) Air Liquide Medical Systems (Chennai))

What seniors require is a pollution free environment, good facilities, good connectivity and courteous service. I find all This at Santosham. The Staff is very helpful and courteous compared to other senior citizen communities. The facilities here are much better and the staff take care of all our needs.



**Mrs and Mr Satish Mudalliar**

Retd from Defence Accounts Dept.

I wanted to give my wife a peaceful environment to stay in with all aspects taken care of after her 65 years of household responsibilities. I also wanted to live in a location close to nature. We love the location and the service provided are also very good. I feel we will have a very refreshing way of life at Santosham.



**Mr. Kesavanarayanan**

Retd Manager - Bank of India

There is no safety for senior citizens in the city. I don't want to be dependent on anyone. At Santosham I feel independent, safe and secure. It is located away from the hectic city life in a beautiful location close to nature which I enjoy immensely Bahri Estates is a name I trust as they have completed several award winning projects before and I am happy to have booked a villa at Santosham.



**Mr. Seetharaman**

Retd from Indian Air Force

The atmosphere is very nice. Santosham suits my budget. All the services as compared to other retirement communities is excellent. I feel my lifespan will be enhanced by another ten years if I stay at this location because it is so peaceful and overall such a lovely place to be at. I love to be here.

**Disclaimer:** Testimonials are individual experiences, reflecting real life experiences of those who have bought our products and/or availed our services in some way or another. However, they are individual and independent opinion and the company shall not any way be held responsible for the same in any manner whatsoever.





## Bahri Estates Pvt. Ltd.

An ISO 9001:2015 Certified Company

### CHENNAI

No. 2E, 2nd Floor, Jamal's Nainar Enclave  
44, Eldams Road, Alwarpet, Chennai - 600 018  
Mobile: +91 90030 03609 / 95000 09541  
Phone: 91 - 44 - 4500 0750 / 51 / 52 / 53  
Fax: 91 - 44 - 4500 0754

### MADURAI

J.Rani Towers, 1st floor, 17 - Bypass Road  
S.S.Colony, Madurai - 625 010  
Mobile: +91 - 96000 23606  
Phone: +91 - 452 - 4500824 / 26

### BENGALURU

2A, 2nd Floor, Lavelle Mansion  
Lavelle Road, Bengaluru - 560 001  
Mobile: +91 - 95000 01455 / 73388 24508  
Phone: + 91 - 80 - 22275222 / 22105522

### DELHI / NCR

No.632, GF, Lane #3, Westend Marg  
Saidullajab, Saket, New Delhi - 110 030  
Mobile: +91 88269 60534  
9971204900 / 9971219400

**TOLL FREE: 1800 102 2111**

[info@bahriestates.com](mailto:info@bahriestates.com) | [www.bahriestates.com](http://www.bahriestates.com)



RERA Reg. No. TN / 021 / Building / 0105 / 2018

**Disclaimer:** The contents and information in this brochure is intended for general marketing purposes only and should not be relied upon being completely accurate by any person. Bahri Estates Pvt. Ltd. its employees, its representatives etc will not accept any liability suffered or incurred by any person working out of or in connection with any reliance of information or content provided in the brochure.

\*The information including the images and materials present in this brochure shall not be deemed to constitute any advertisement, invitation, solicitation, offer or sale of any units in any Project.